

Flue Installation

The Wagener Leon uses a 150mm diameter flue. It is imperative that the connection between the flue and the flue spigot is sealed using a recommended flue sealant. If an offset bend is required it should be as steep as possible to enable ease of cleaning. Extra flue height may be required to compensate for lack of draw. **The performance of the Wagener Leon depends more on the flue than on any other single component as it is the draw on the flue that drives the Wagener Leon. We recommend 4.2 metres of flue.**

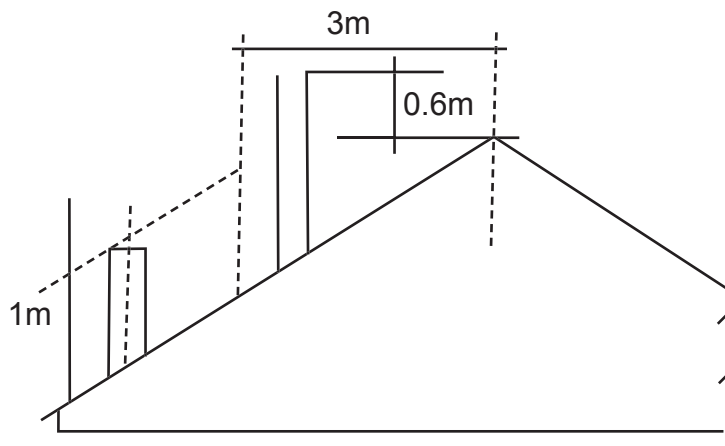

The top of the flue system should be at least 1000mm above the roof or at least 600mm higher than any obstacle or ridge within 3 metres of the flue.

A total minimum vertical flue height ABOVE the Wagener Leon of 4.2 metres is normally required for adequate draft.

Joints between sections of the flue pipes are push fitted so that the upper section enters the bottom section and must be SEALED using a flue sealant.

Each section should be secured to prevent separation using 3 stainless steel self tapping screws or pop rivets. Only flue systems which comply with the AS/NZS 2918-2001 should be used.

Please follow flue manufacturers instructions on page 5 "150mm Free Standing Woodfire Flue Kit Installation" Instructions'. **NB. Bird netting is available**

