

Part I: INSTALLATION INSTRUCTIONS FOR THE BUTLER MULTI

(Please keep these Instructions for future Reference)

Important Message to the Owner

Please read fully the Operation & Maintenance Instructions with your Butler Multi **BEFORE** lighting your first fire. Your insurance company may require notification of the installation. Please check.

When a Wet Back is fitted it must be connected to the water supply or damage will result.

Such damage is not covered by Warranty. Tempering Valves should be installed to the system for safety. Tempering Valves may be a Permit Requirement. Check with your Building Inspector or Local Council.

BIA: As from 22 April 2003 Automatic Smoke Detectors/Alarms will be mandatory in all new homes and when solid fuel heating appliances are installed. Permits will not be signed off if alarms are not fitted.

Important Message to the Installer

The Butler Multi has been tested to and complies with AS/NZS 2918:2001- Domestic Solid Fuel Burning Appliances

The Butler Multi must be installed in accordance with these installation instructions to comply with AS/NZ 2918-2001-Domestic Solid Fuel burning appliances.

Installer's Responsibilities

Installation of the Butler Multi must be in accordance with these instructions.

Any variation from these installation instructions or any doubts about them must be checked against requirements of the AS/NZS 2918-2001. The installation must be carried out by a suitably qualified installer. We recommend using an NZHHA Accredited Technician.

WARNING: THE APPLIANCE AND FLUE SYSTEM SHALL BE INSTALLED IN ACCORDANCE WITH AS/NZS 2918: 2001 AND THE APPROPRIATE REQUIREMENTS OF THE RELEVANT BUILDING CODE OR CODES.

THE APPLIANCE AND FLUE SYSTEM SHOULD NOT BE MODIFIED IN ANY WAY WITHOUT THE WRITTEN APPROVAL OF THE MANUFACTURER.

WARNING: DO NOT CONNECT WET BACKS TO AN UNVENTED HOT WATER SYSTEM

INSTALL IN ACCORDANCE WITH AS 3500.4.1 OR NZS 4603 AND THE APPROPRIATE REQUIREMENTS OF THE RELEVANT BUILDING CODE OR CODES

CAUTION: MIXING OF APPLIANCE OR FLUE SYSTEM COMPONENTS FROM DIFFERENT SOURCES OR MODIFYING THE DIMENSIONAL SPECIFICATION OF COMPONENTS MAY RESULT IN HAZARDOUS CONDITIONS. WHERE SUCH ACTION IS CONSIDERED, THE MANUFACTURER SHOULD BE CONSULTED IN THE FIRST INSTANCE.

CAUTION: CRACKED AND BROKEN COMPONENTS, e.g. GLASS PANELS OR FIRE BRICKS MAY RENDER THE INSTALLATION UNSAFE.

Flue System

Must be manufactured in accordance with AS/NZ 2918-2001 and tested to Appendix F. See installation instruction section on page 5.

PLEASE LEAVE THESE INSTRUCTIONS WITH THE OWNER WHEN THE INSTALLATION IS COMPLETED

PRELIMINARY INSTALLATION PROCEDURES FOR THE BUTLER MULTI

To get full benefit from the Butler Multi it is important that it is installed correctly, both for efficiency and safety sake. The following points should be noted:

1. The characteristics of the Butler Multi will determine its position within the home. As a general rule an interior wall installation suits flue requirements better than against an exterior wall.
2. Check for flue obstructions above the ceiling. (e.g. header tanks, electrical mains or load bearing roof supports).
3. The minimum vertical flue height for satisfactory operation is 4.2metres above the top of the Butler Multi Flue Flange. The performance of the Butler Multi depends more on the flue than on any other single component. It is the draw on the flue that drives the stove.
4. Remember a permit is required from your Local Authority.

Floor Protector/Hearth Requirements

The MINIMUM requirement for the Butler Multi with a wet back fitted or as a DRY model is an ASH HEARTH only.

The Floor Protector shall extend under the appliance and NOT Less than the width of the Appliance and shall extend 300mm forward and 200mm each side of the Fuel Loading/Ash-Removal opening.

The Ash Hearth shall have an upper surface, including grouting, of durable, non-combustible material. All joints in the surface must be sealed to protect and prevent ash or spilled embers reaching the floor. For concrete floors trim any floor coverings to the same minimum hearth requirement.

NOTE: THE BUTLER MULTI MUST BE AFFIXED TO THE HEARTH AND FLOOR FOR SEISMIC RESTRAINT.

For Seismic Restraint use two holes in the base at the rear and screw through the hearth and into the floor.

NOTE: FOR DRY MODEL AND SPECIAL 2KW WET BACK MODEL PLEASE SEE SEPARATE DRY INSTALLATION INSTRUCTION SHEET AS CLEARANCES ARE DIFFERENT.

Wet Back Fitting

The Butler Multi is fitted with a wet back unless a Dry Model is requested.(see separate specification sheet)

We recommend that you use the "Lion" Wet Back which has been designed and tested specifically for the Butler Multi. In general, wet backs are factory fitted at the time of ordering.

However, a suitably qualified person can fit or change the wet back out in the field if this is required.

Water must always be present in the wet back.

The wet back MUST be connected by a Registered Plumber to an open vented system.

Tempering valves are required.

Please check the PH level of the water supply as wet backs can become fouled with lime which will void the warranty.

NB Some coals are very corrosive and may shorten the life of the wet back – please check with the supplier as this is NOT covered by warranty.

Please advise the householders NOT to boil the wet back as this will cause vibrations and will fatigue the wet back, the pipes and the cylinder. This will NOT be covered by the warranty.

Baffle & Brick Assembly for Wet Back Model

Position the baffle on the ledge in the top, central chamber of the wet back, in the ceiling of the firebox.

The round rods on the baffle should face downwards. The baffle should then be pushed back so that there is no gap at the rear. Position the bricks so that they tuck up under the edge of the wet back.

BUTLER MULTI WET 6KW

Fitted with a standard 6kw "Lion" Wet Back only

Wet Installation Clearances

AS/NZ Standard 2918:2001

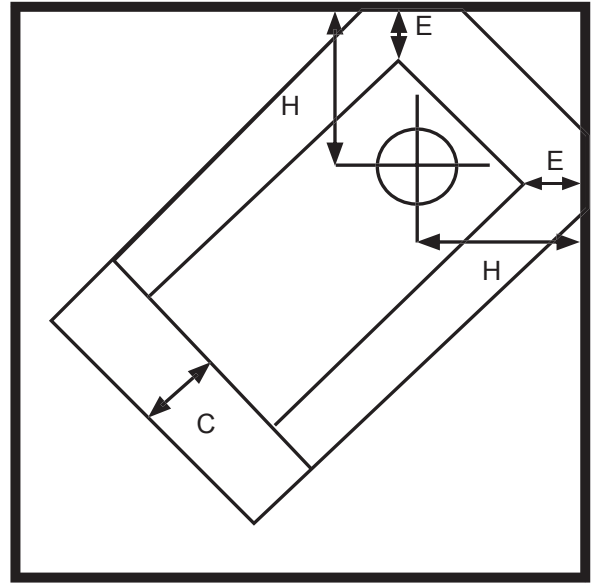
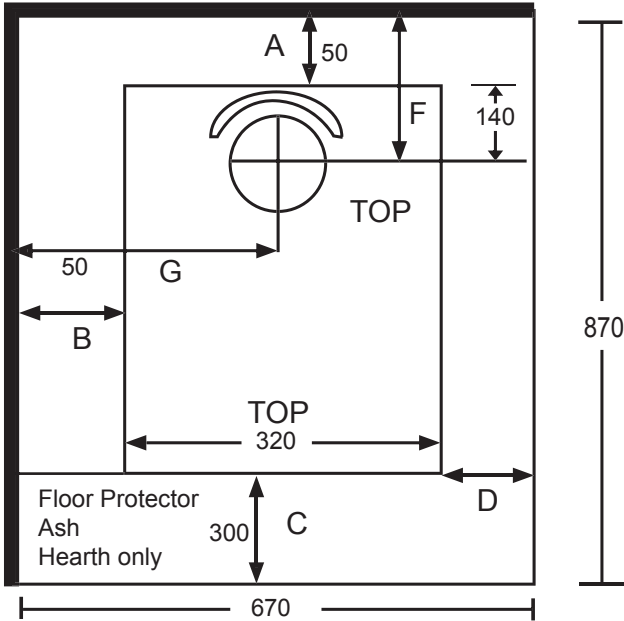

Estimated Heat Output 8kw (depending on fuel used)

Estimated Hot Water Output 6kw

Minimum clearance to Combustible Surfaces	A	B	C	D	E	F	G	H
With double stainless steel Flue shield to unprotected wall	50mm	50mm *(25mm)	300mm	175mm	25mm	190mm	210mm *(185mm)	240mm
As above 12mm Eterpan LD board spaced 25mm off wall	37mm	37mm	Ash Hearth Floor Protection must extend under the stove and forward 300mm extending 200mm either side of the door opening		* 1. One side wall clearance can be reduced to 25mm by rotating the flue shield 45 deg 2. Bench height side wall only (not above top of heater) clearance 25mm.			
As above with sheet metal any type 0.5mm or thicker spaced 25mm off the wall.	25mm	25mm						

Other screening materials are available and clearance factors can be calculated to the AS/NZS 2918:2001. Please ask your retailer or contact Wagener Stoves if you need further advice.

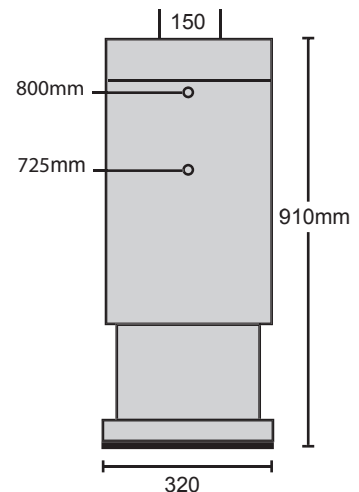
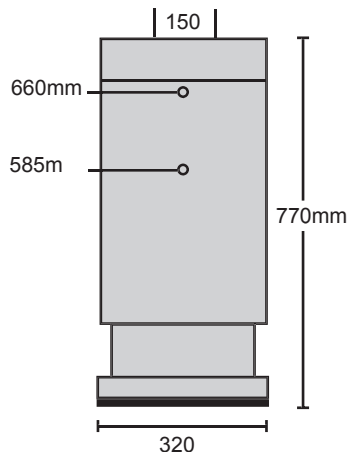
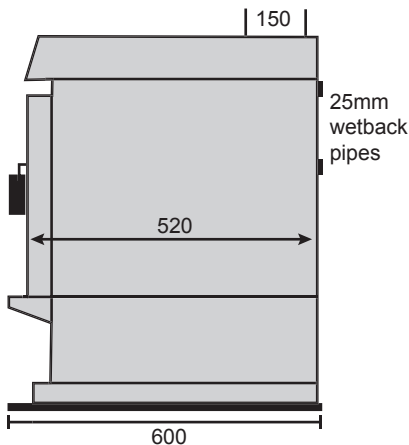

FLUE INSTALLATION 3/05

The Butler Multi uses a 150mm diameter flue. It is imperative that the connection between the flue and the flue spigot is sealed using a recommended flue sealant. If an offset bend is required it should be as steep as possible to enable ease of cleaning. Extra flue height may be required to compensate for lack of draw. **The performance of the Butler Multi depends more on the flue than on any other single component as it is the draw on the flue that drives the Butler Multi. We recommend 4.2metres of flue.**

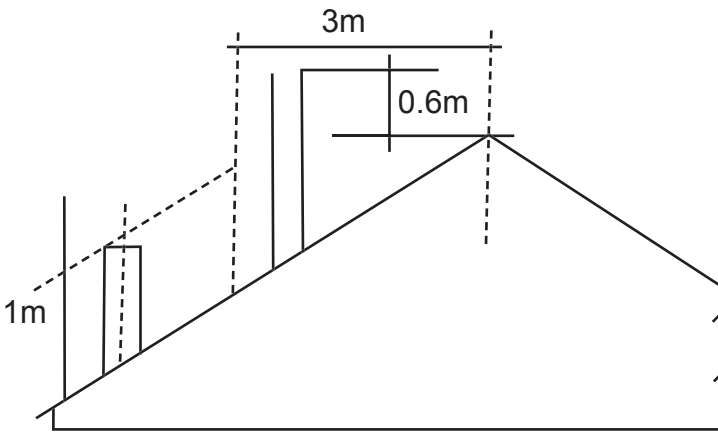

The top of the flue system should be at least 1000mm above the roof or at least 600mm higher than any obstacle or ridge within 3 metres of the flue. A total minimum vertical flue height ABOVE the Butler Multi of 4.2 metres is normally required for adequate draft. Joints between sections of the flue pipes are push fitted so that the upper section enters the bottom section and must be SEALED using a flue sealant. Each section should be secured to prevent Separation using 3 stainless steel self tapping screws or pop rivets. Only flue systems which comply with the AS/NZS 2918-2001 should be used. Please follow flue manufacturers instructions on page 5 "150mm Free Standing Woodfire Flue Kit Installation" Instructions'. ***NB. Bird netting is available***

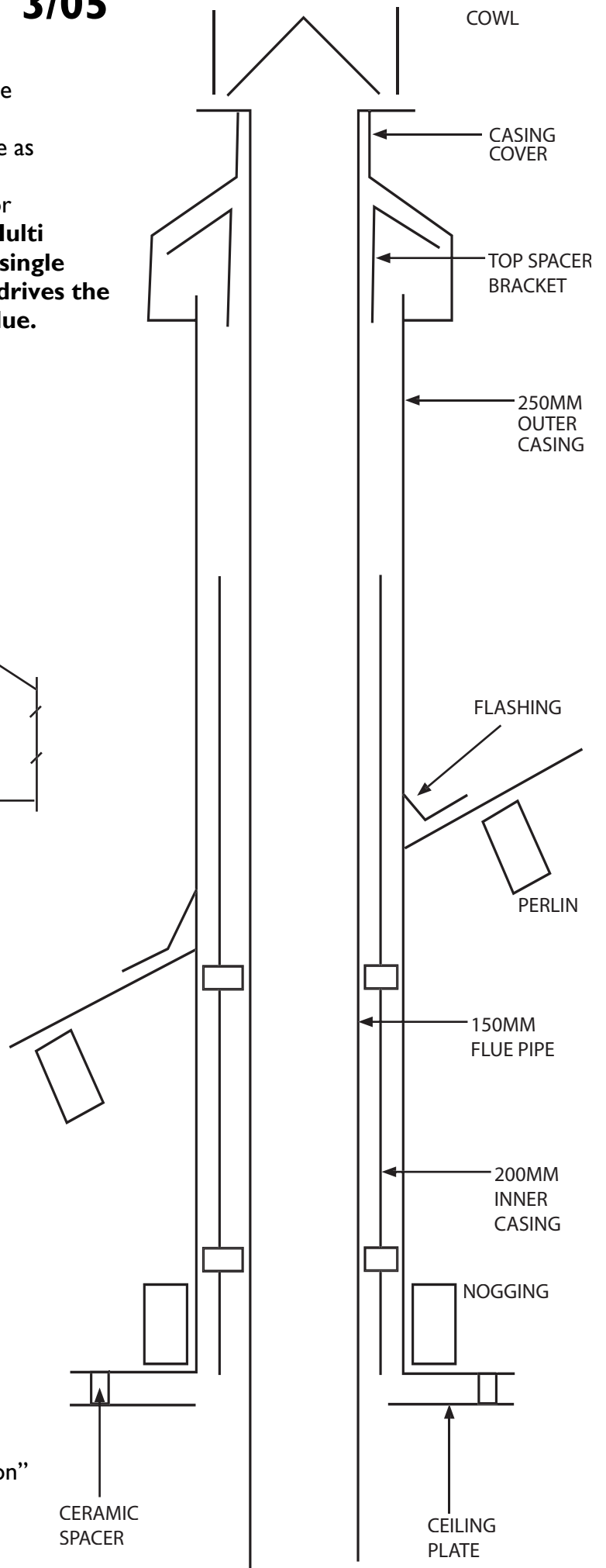

150 MM FREE STANDING WOODFIRE FLUE KIT INSTALLATION INSTRUCTIONS (See illustration Page 4)

This flue kit has been manufactured in accordance with AS/NZS 2918:2001 and tested to appendix F. To ensure safety this flue kit must be installed as outlined in these instructions. Heater and flue clearances from combustible walls must be in accordance with heater manufacturer's specifications and AS/NZS 2918:2001. These installation instructions are for tested appliances only.

1. Locate heater in its proposed position and mark a point on the ceiling that is directly above the centre of the heater's flue outlet. Check that the heater's location allows the OUTER HEAT SHIELD to clear all structural roof timbers.
2. Cut a 260mm square hole in the ceiling. Directly above cut a hole in the roof to accommodate OUTER HEAT SHIELD.
3. Fit timber nogs around ceiling and roof holes. i.e. Nogs form a 260mm square aperture which allows air to circulate freely over the OUTER HEAT SHIELD surface.
4. Position the OUTER HEAT SHIELD so that it is flush with the underneath of the ceiling and protrudes through the roof the required height. (Refer to AS/NZS 2918/2001 if more details are required). When calculating roof penetration height allow for an extra 500mm that can be achieved by using the OUTER HEAT SHIELD SLIP EXTENSION.
 - a) If the flue is within 3 metres of the ridge, the OUTER HEAT SHIELD must protrude at least 600mm above the ridge of the roof.
 - b) If the distance from the ridge is more than 3 metres, the OUTER HEAT SHIELD must protrude at least 1000mm above roof penetration.

Additional OUTER HEAT SHIELD and INNER SHIELD (BAFFLE) may have to be added to ensure the correct roof penetration heights are obtained.

5. Fix an appropriate flashing around the OUTER HEAT SHIELD to seal onto the roofing material.
6. From the roof slide the INNER SHIELD into the OUTER HEAT SHIELD until it rests 12mm above ceiling level.
7. Assemble FLUE PIPES together ensuring seams are in line. Secure each joint with 3 rivets or self-tapping screws. FLUE PIPES must be assembled with crimped ends down. (towards heater)
8. Place CEILING PLATE over heater flue spigot, ensuring the folded edge upstands are facing the ceiling.
9. From the roof lower FLUE PIPE through OUTER HEAT SHIELD into position.
10. Before securing the OUTER HEAT SHIELD SLIP EXTENSION to the OUTER HEAT SHIELD with 3 rivets or self tapping screws, ensure the FLUE PIPE extends above the top of the OUTER HEAT SHIELD SLIP EXTENSION 145mm. Adjust SLIP EXTENSION to obtain this measurement. If minimum roof penetration heights described earlier can not be achieved add sufficient stainless steel FLUE PIPE.
11. Fit TOP FLUE SPACER BRACKET to the FLUE making sure the lugs fit snugly inside OUTER HEAT SHIELD SLIP EXTENSION. Make sure TOP FLUE SPACER BRACKET fits hard down onto OUTER HEAT SHIELD SLIP EXTENSION.
12. Fit CASING COVER over the FLUE PIPE and push down firmly onto TOP FLUE SPACER BRACKET. Secure with a rivet or self-tapping screw.
13. Fit COWL but do not secure, as removal for flue cleaning will be necessary.
14. Fasten CEILING PLATE to ceiling using screws and spacers provided. Ensure an even air gap around FLUE PIPE when fixing. Remove protective plastic from CEILING PLATE.

N.B. It is the responsibility of the installer to ensure that the installation of this flue kit complies with AS/NZS 2918:2001, the appliance manufacturers specifications for flues and that relevant Local Body requirements are adhered to.

Part 2: OPERATION & MAINTENANCE

INSTRUCTIONS FOR THE BUTLER MULTI 3/05

Message to the Owner

Thank you for purchasing the Butler Multi.

With care and common sense the Butler Multi will give you many years of trouble free service.

We recommend an annual safety check of flues, bricks, door seals, door catches, air controls and the like.

WARNINGS AND CAUTIONS

1. **WARNING: ANY MODIFICATION OF THE APPLIANCE THAT HAS NOT BEEN APPROVED IN WRITING BY THE TESTING AUTHORITY IS CONSIDERED AS BREACHING AS/NZS 4013.**
2. **WARNING: DO NOT USE FLAMMABLE LIQUIDS OR AEROSOLS TO START OR REKINDLE THE FIRE.**
3. **WARNING: DO NOT USE FLAMMABLE LIQUIDS OR AEROSOLS IN THE VICINITY OF THIS APPLIANCE WHEN IT IS OPERATING.**
4. **WARNING: DO NOT STORE FUEL WITHIN HEATER INSTALLATION CLEARANCES.**
5. **WARNING: DO NOT OPERATE THIS APPLIANCE AS AN OPEN FIRE. IT IS NOT TESTED TO BE USED IN THIS WAY AND WILL BE CONSIDERED AS BREACHING AS/NZS2918:2001.**
6. **WARNING: OPEN AIR CONTROL TO FULL AIR SUPPLY BEFORE OPENING FIRE DOOR.**
7. **CAUTION: THIS APPLIANCE SHOULD NOT BE OPERATED WITH A CRACKED GLASS.**
8. **CAUTION: THIS APPLIANCE SHOULD BE MAINTAINED AND OPERATED AT ALL TIMES IN ACCORDANCE WITH THESE INSTRUCTIONS.**
9. **CAUTION: THE USE OF SOME TYPES OF PRESERVATIVE-TREATED WOOD AS A FUEL CAN BE HAZARDOUS.**

Further Cautions & Over Firing

Never use the Butler Multi with the door ajar or open. This will cause over firing and damage to your stove & flue which will NOT be covered by warranty as well as being potentially dangerous. **SIGNS OF OVER FIRING:** Flue turns red hot and stove “roars”.

POSSIBLE CAUSE OF OVER FIRING

1. Excess flue length/ windy conditions
2. Door Ajar
3. Faulty door seal
4. Full load of very dry, small wood
5. Dirty flue catches fire

REMEDY

- Move Air Control to reduce or close air supply
- Close door
- Replace faulty door seals
- Don't load excess fuel
- Close Air Supply. Call fire brigade if necessary.
Inspect & Clean Flue when cold.

The Butler Multi is HOT while in operation and contact may cause burns.

CREOSOTE OR SOOT FIRE: In the unlikely event of a soot or creosote fire occurring see Remedy 5 above.

OPERATING YOUR BUTLER MULTI 3/05

Fuels – Wood & Coal

1. **Wood** - Dry, seasoned wood should be used at all times and, as a general rule, the harder the wood the longer it will burn.

Try to buy wood well in advance and store so that the air can circulate through the pile to assist drying. Wet, unseasoned wood (under 12 months old) can cause creosote problems, especially if it is burned slowly. If unseasoned fuel is used, special care should be taken to ensure that the fire is actually burning and not just smouldering which will precipitate a creosote problem.

DO NOT burn driftwood or treated timber as they will damage your Butler Multi and flue and void your warranty.

2. **Coal** – To burn coal you will need to start the fire with wood to establish a good base fire bed of hot embers. Then add coal a little at a time allowing the coal to burn before adding more. Once the desired fuel load has been added and is burning well adjust the air controls to achieve desired burn rate.

WARNING: Some coal types are very corrosive to the fire box, flue and wet back. Corrosion is not covered by the warranty – please check with your coal supplier.

NOTE: The Heat output of the Butler Multi is controlled not only by the air controls but also by the type and quality of fuel in the firebox.

First Burn for a New Appliance or Repainted Appliance

On INITIAL LIGHTING, the high temperature paint used on the Butler Multi will give off smoke and odour for a short period. This is a temporary condition.

Open doors and windows to give adequate ventilation.

To condition the firebricks (ie remove moisture to prevent cracking) your first 2-3 fires must be small.)

Start Up

1. Slide the air control (black knob above the door) to select the HIGH position for full air supply. Rotate the lower air control on the door to fully open.
2. Open the firebox door. Place crumpled newspaper on top of the firebox grate (if using firelighters place firelighters under the newspaper). Stack kindling around it like an Indian Tepee and light the newspaper (or firelighters), then close the firebox door. Once the kindling is well alight add slightly larger pieces of wood until you have a good healthy fire. **If burning coal see instructions above.**
3. Refuel once the fire is established.
4. Adjust the air controls to the desired setting when fire is burning well.
5. It should not be necessary to fill the firebox to capacity. Smaller loads of wood or coal burned on half air supply will produce more heat per kg of wood/coal. Flue length and outside wind may affect the performance of the fire.
6. Over Firing will damage your stove & flue system and will void your warranty. Please refer to page 6 - Signs of Over Firing, Causes and Remedies.

Stove Top Cooking

Establish a good fire and allow the Butler Multi to heat up. Never cook food directly on the top of the stove. The Butler Multi is not a BBQ. Always use kettles, pots and appropriate cooking implements.

Slow Burning

Ensure that your Air Control is fully open and that you have a good base of hot embers. Add a full load of larger pieces of hardwood or coal. Allow to burn for 10-20 minutes before adjusting the Air Controls to low (almost closed position).

The Butler Multi will now burn away for long periods on low.

Reloading after a Slow Burn

At the end of a slow burn adjust the air controls to the high position for maximum air supply.

Rake the embers and re-establish the fire by adding a few small split logs and allow the firebox temperature to build up before adding the balance of the fuel.

The addition of large quantities of cold fuel to a low fire will reduce the firebox temperature dramatically and this may result in 'losing' the fire. Proceed with fire as before.

MAINTENANCE AND CLEANING 3/05

Ensure that your Butler Multi is cold and that there are no hot embers in the fire box.

The outside enamel panels of your Butler Multi may be cleaned with a soft rag and non abrasive "spray & wipe" type products.

Ash Removal

Over a period of time ash will build up in your Butler Multi requiring removal.

Ash build-up will depend upon the quality and quantity of your fuel.

To empty ashes from the fire box, rake ashes on the grate with poker, to loosen and allow to fall through to ash pan below. Dispose of contents of ash pan in a non-combustible container with a tightly fitting lid.

Place outdoors immediately to a location clear of combustible materials.

Door Glass

Under normal operating conditions, using seasoned fuel, the glass in your Butler Multi should remain relatively clear. If the glass becomes dirty it can be cleaned by dipping a damp paper towel into the dry cold ashes, and rubbing gently on the dirty glass to clean. If in the unlikely event your door glass breaks it must be replaced with a 5mm ceramic glass. This can be purchased through your Wagener Stoves Dealer.

NOTE: Do not operate your Butler Multi with broken glass and under no circumstance should a non-ceramic type glass be used as it may explode due to the intense heat inside the fire box.

The Door Seals

The door seal should be checked and adjusted to provide a perfect seal at all times. Excess air entering the fire box past a faulty seal will make it impossible to achieve a slow burn, and may result in over firing the Butler Multi and causing damage.

Fire Box Bricks

Fire Bricks serve two purposes. Firstly, to protect the steel chassis and secondly to maintain high temperatures in the fire box to effect complete combustion of the fuel. Cracked and broken bricks should be replaced. Remember to place your fuel in the firebox rather than throwing it in. This will extend the life of your bricks.

Flue Cleaning

Flue cleaning and maintenance is probably best done by a professional who can also advise you on the condition of your flue and other parts like bricks and seals. This should be done annually. However, if you are cleaning the flue yourself first allow the fire to go out and the Butler Multi to cool down. Remove the cowl and rod the flue downwards from the roof. Remove the baffle to clean out the soot from the firebox. Alternatively remove the baffle and rod the flue upwards, from inside, through the open firebox door.